UNITRON®

MEC2

**INVERTED METALLURGICAL
MICROSCOPE**



MANUAL



CONTENTS

SAFETY NOTES	3
CARE AND MAINTENANCE	3
INTRODUCTION	4
UNPACKING AND COMPONENTS	4
COMPONENT DIAGRAMS	4-5
ASSEMBLY	5
DETAILED ASSEMBLY PROCEDURE	6
ADJUSTMENT AND OPERATION	
TURNING ON THE LAMP	10
ADJUSTING THE BRIGHTNESS	10
ADJUSTING THE TENSION ADJUSTMENT COLLAR	10
ADJUSTING THE ILLUMINATION	11
PLACING AND MOVING THE SPECIMEN	12
ADJUSTING THE DIOPTER	13
ADJUSTING THE INTERPUPILLARY DISTANCE	13
SWITCHING THE LIGHT PATH	13
MICROSCOPE VIDEO AND PHOTOGRAPHY	14
SPECIFICATIONS	16
TROUBLESHOOTING	17
MAINTENANCE	18
SERVICE	18
WARRANTY	12

SAFETY NOTES

1. Open the shipping carton carefully to prevent any accessory, i.e. objectives or eyepieces, from dropping and being damaged.
2. Keep the instrument out of direct sunlight, high temperature or humidity, and dusty environments.
3. If any specimen solutions or other liquids splash onto the stage, objective or any other component, disconnect the power cord immediately and wipe up the spillage. Otherwise, the instrument may be damaged.
4.  **LAMP REPLACEMENT -- CAUTION:** the glass envelope of the lamp may be extremely hot. DO NOT attempt to change the lamp before it is completely cooled or without wearing adequate skin protection.
5. All electrical connectors (power cord) should be inserted into an electrical surge protector to prevent damage due to voltage fluctuations.
6.  **FUSE REPLACEMENT --** For safety when replacing the fuse (ONLY replace with the same size, type and rating of original fuse), be sure the main switch is in the off position, disconnect the power cord from outlet, and replace the fuse. Reconnect the power cord and turn unit on.
7. Confirm that the input voltage indicated on your microscope corresponds to your line voltage. The use of a different input voltage other than indicated will cause severe damage to the microscope. NOTE: Always plug the stereomicroscope power cord into a suitable grounded electrical outlet. A grounded 3-wire cord is provided.

CARE AND MAINTENANCE

1. Do not attempt to disassemble any component including eyepieces, objectives or focusing assembly.
2. Keep the instrument clean; remove dirt and debris regularly. Accumulated dirt on metal surfaces should be cleaned with a damp cloth. More persistent dirt should be removed using a mild soap solution. Do not use organic solvents for cleansing.
3. The outer surface of the optics should be inspected and cleaned periodically using an air stream from an air bulb. If dirt remains on the optical surface, use a soft, lint free cloth or cotton swab dampened with a lens cleaning solution (available at camera stores). All optical lenses should be swabbed using a circular motion. A small amount of absorbent cotton such as a Q-tip or cotton swab, makes a useful tool for cleaning recessed optical surfaces. Avoid using an excessive amount of solvents as this may cause problems with optical coatings or cemented optics or the flowing solvent may pick up grease making cleaning more difficult.
4. Store the instrument in a cool, dry environment. Cover the microscope with the dust cover when not in use.
5. UNITRON® microscopes are precision instruments which require periodic servicing to maintain proper performance and to compensate for normal wear. A regular schedule of preventative maintenance by qualified personnel is highly recommended. Your authorized UNITRON® distributor can arrange for this service.

INTRODUCTION

Congratulations on the purchase of your new UNITRON® microscope. UNITRON® microscopes are engineered and manufactured to the highest quality standards. Your microscope will last a lifetime if used and maintained properly. UNITRON® microscopes are carefully assembled, inspected and tested by our staff of trained technicians in our New York facility. Careful quality control procedures ensure each microscope is of the highest quality prior to shipment.

UNPACKING AND COMPONENTS

Your microscope arrived packed in a molded shipping carton. ***Do not discard the carton:*** the shipping carton should be retained for reshipment of your microscope if needed. Avoid placing the microscope in dusty surroundings or in high temperature or humid areas as mold and mildew can form. Carefully remove the microscope from the shipping carton and place the microscope on a flat, vibration-free surface.

COMPONENT DIAGRAMS

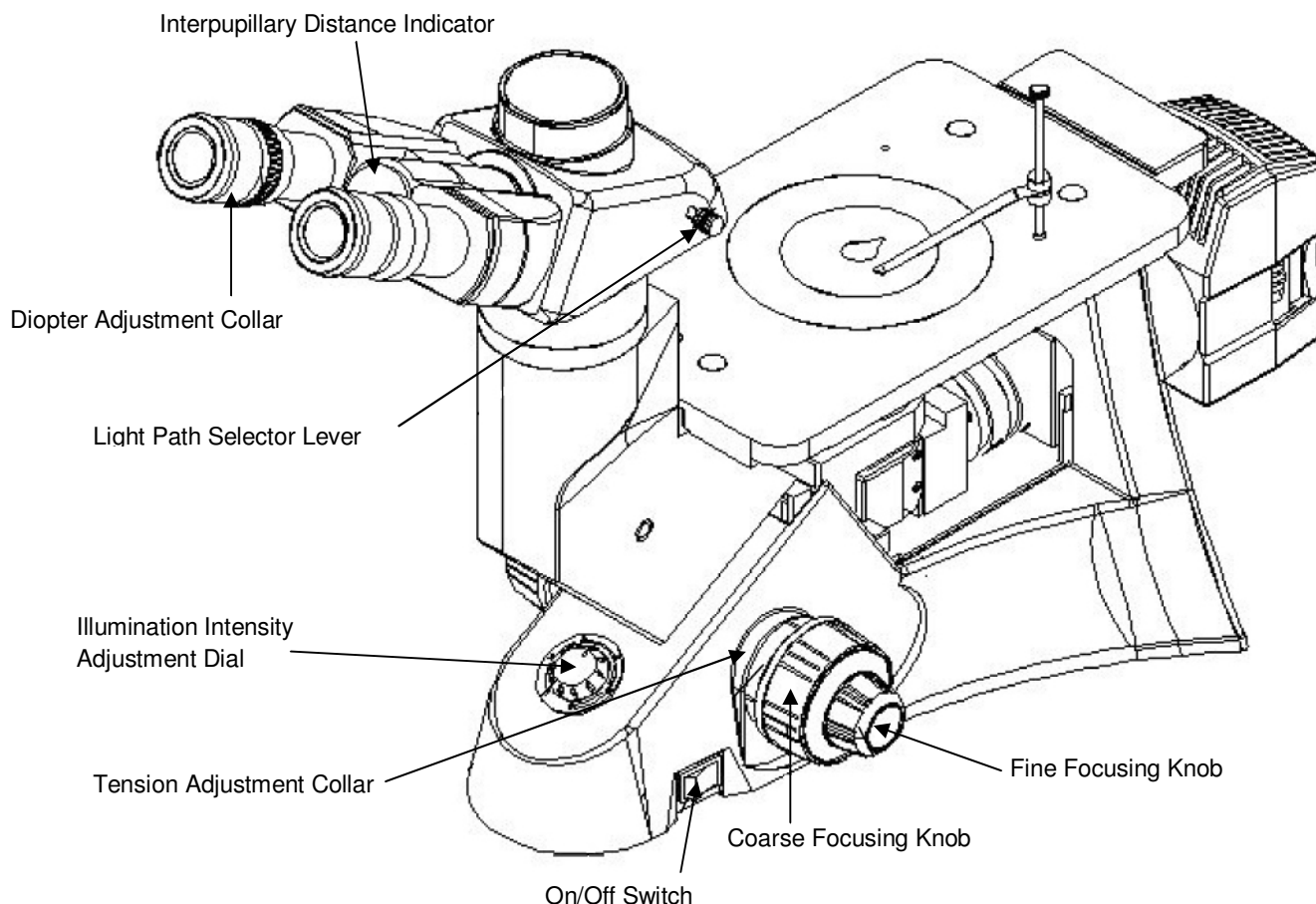

MEC2 INVERTED METALLURGICAL MICROSCOPE

COMPONENT DIAGRAMS *(continued)*

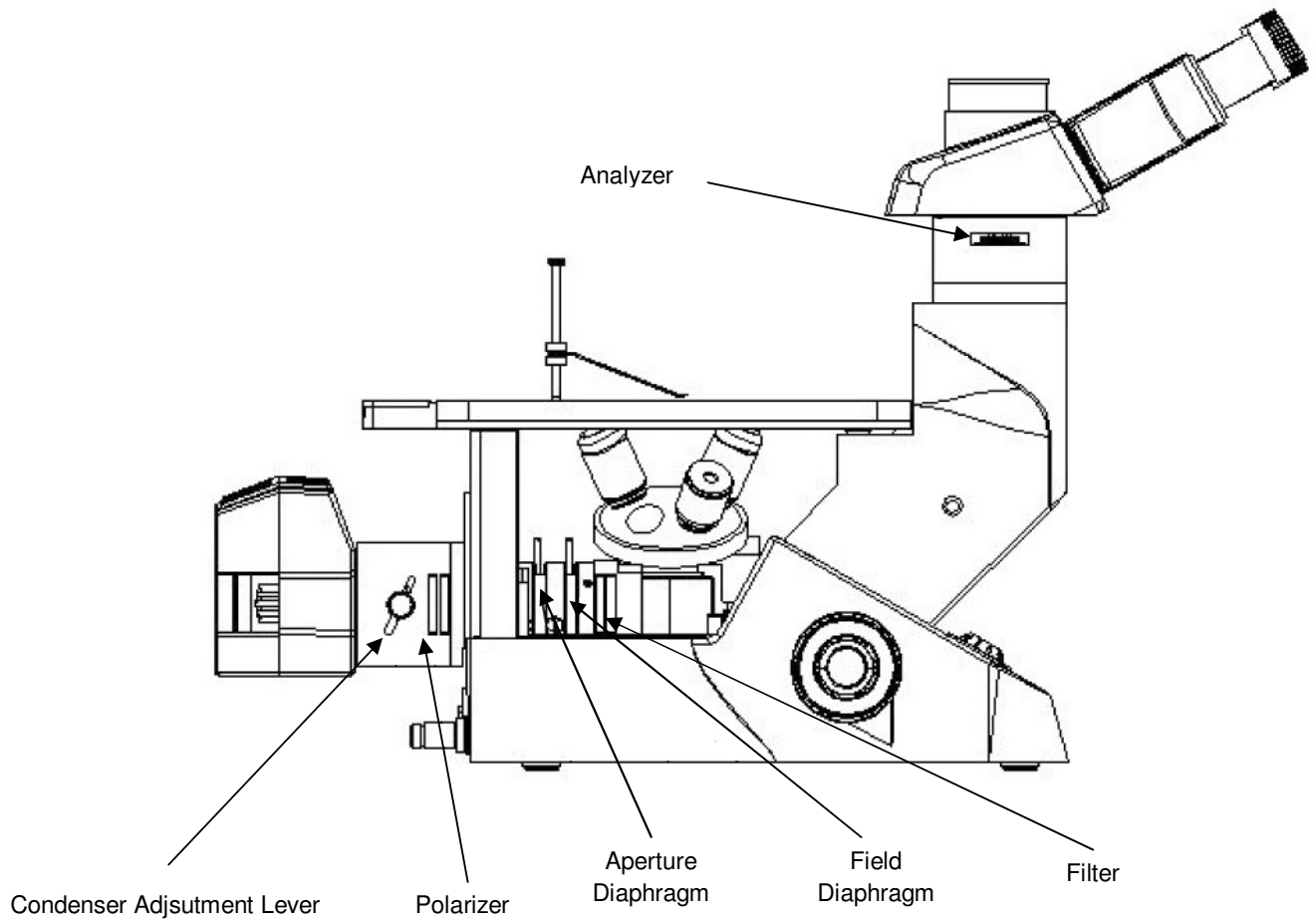

DETAILED ASSEMBLY PROCEDURE

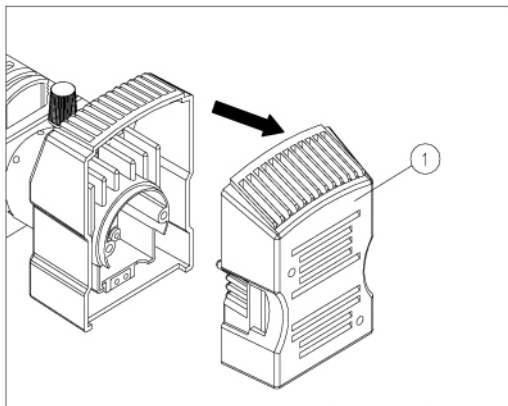

Fig. 1

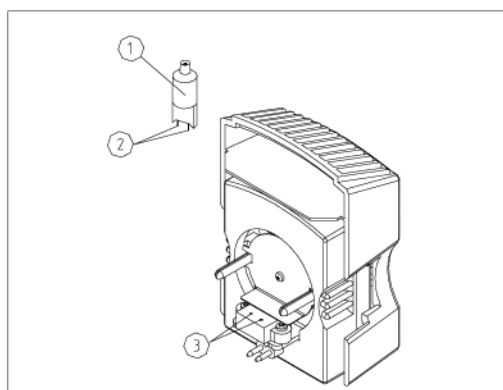

Fig. 2

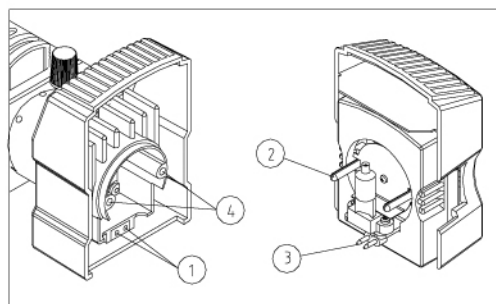

Fig. 3

Attaching the Mechanical Stage And X-Y Controls

The mechanical stage may be installed in either side of the stage to enlarge the stage surface. The x-y controls must be installed on the opposite side of the auxiliary stage.

Generally, the x-y controls are installed on the right side for comfortable operation.

Installing The Mechanical Stage

Screw the clamping bolts into to the mechanical stage, then into the fixed stage from below on either the right or left side. Tighten the bolts with a screwdriver until the mechanical stage is securely attached.

Installing The X-Y Controls

Install the ruler using the same method as the mechanical stage.

Installing and Replacing the Halogen Bulb (Figures 1-3)

Use only the specified halogen lamp: 6V 30W

1. Pull out the lamp house① (Figure 1)
2. Holding the bulb ① with a piece of gauze or other protective material, insert the bulb pins straight and fully into the pin holes③ on the lamp house. (Figure 2)

CAUTION: The bulb, lamp housing and nearby parts will be very hot during usage.

3. When replacing the lamp, turn the main switch to "O (off)" and remove the power cord. Allow the lamp, lamp house and adjacent areas to sufficiently cool before handling. The lamp can become very hot and will cause burns.

MEC2 INVERTED METALLURGICAL MICROSCOPE

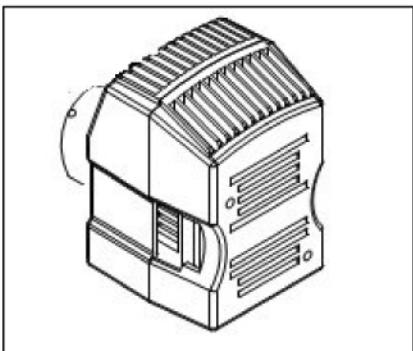

Fig. 4

Insert the lamp gently but firmly into the socket.

Do not touch the halogen bulb with bare fingers. Doing so will shorten the service life of the lamp.

If you leave fingerprints on the lamp surface, clean it with a soft cloth or lint free paper.

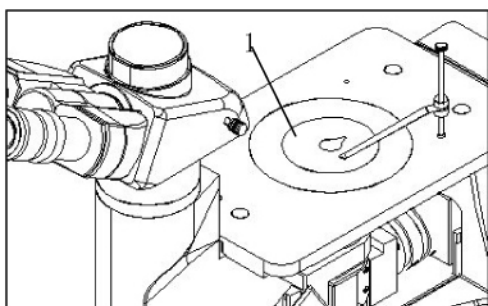

Fig. 5

4. Align the socket ① with the pins ③, and the bolts ② with the jacks ④. Then insert the lamphouse cover completely into place. (Figures 3 & 4)

Installing the Stage Plate (Figure 5)

The stage plate ① is installed by placing it in the center of fixed stage.

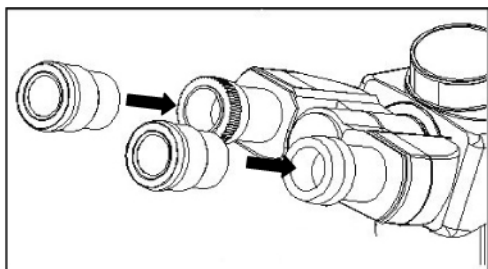

Fig. 6

Installing the Eyepieces (Figure 6)

1. Remove the protective caps on the eyepiece tubes.

2. Insert the eyepieces into eyepiece tubes until they are completely inserted.

Installing the Video Adapter

(Figures 7, 8, & 9)

Insert the video adapter tube (Figure 7) into the trinocular viewing head (Figure 8) and tighten the thumb screw (Figure 9 – next page).

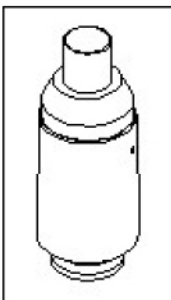

Fig. 7

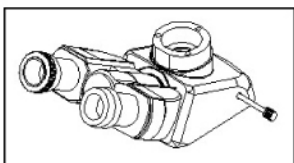

Fig. 8

MEC2 INVERTED METALLURGICAL MICROSCOPE

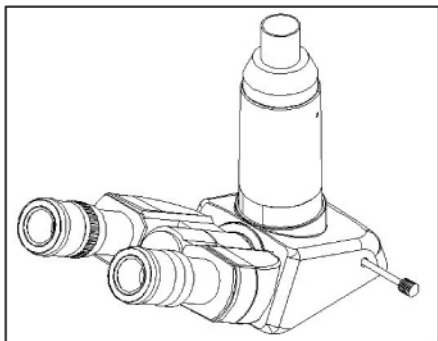

Fig. 9

Mounting Filters and Polarizer (Figure 10)

1. Insert a standard filter(s) into slot (1)
2. For polarized observation, insert the polarizer filter into slot (2).

Standard filters are blue, yellow and green filters

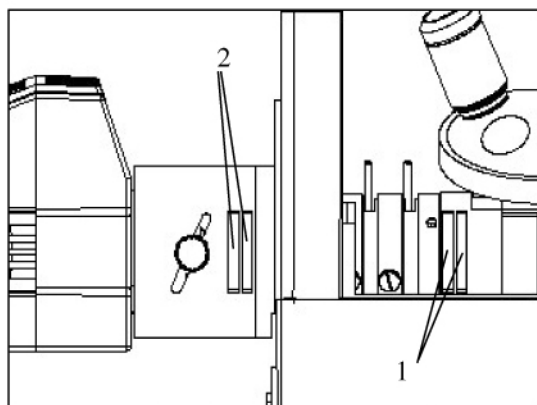

Fig. 10

Mounting the Analyzer (Figure 11)

Insert the analyzer (3) into the slot under the trinocular viewing head.

The analyzer may be used alone or with the polarizer.

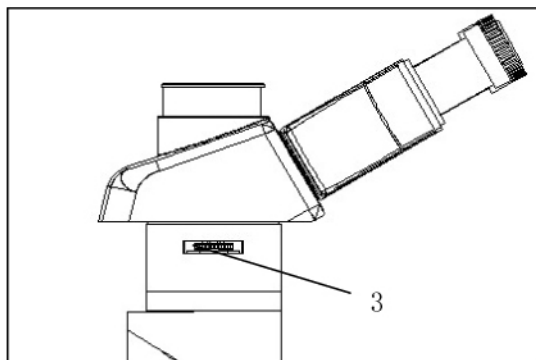

Fig. 11

MEC2 INVERTED METALLURGICAL MICROSCOPE

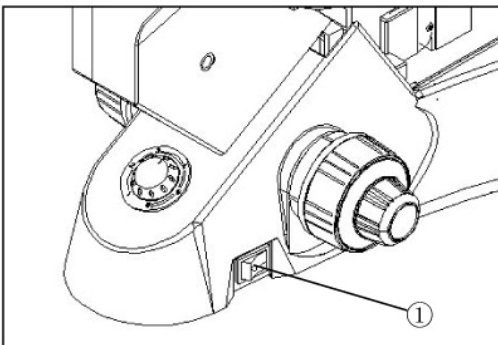

Fig. 12

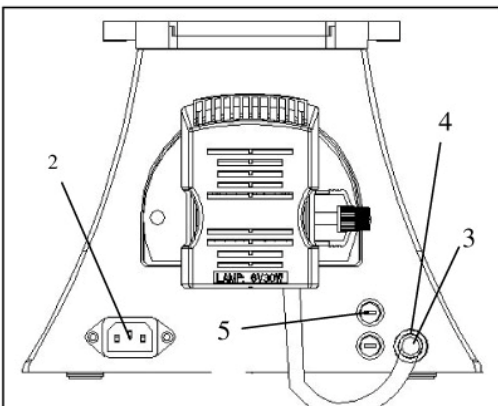

Fig. 13

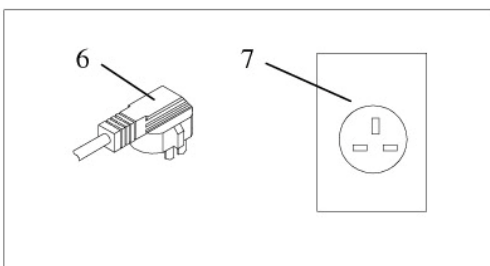

Fig. 14

Connecting the Power Cord

(Figures 12, 13 & 14)

The electric cord should never be bent, twisted, crushed or subjected to stress.

1. Set the main switch ① to “O” (off) before connecting the power cord.
2. Insert the power cord into the receptacle ②.
3. Insert the BNC cord plug (3) into the BNC connector (4).

Ensure the power cord is connected to a properly grounded electrical outlet.

Replacing the Fuse (Figures 12 & 13)

Ensure the main switch ① is set to “O” (Off) and the power cord is disconnected before replacing the fuse. With a flat-head screwdriver, remove the fuse holder (5), replace with a new fuse, then re-install the fuse holder.

Fuse rating: 250V, 500mA

Connecting the Power Cord

(Figure 14)

Insert the power cord (6) into a properly grounded 3-prong electrical outlet (7).

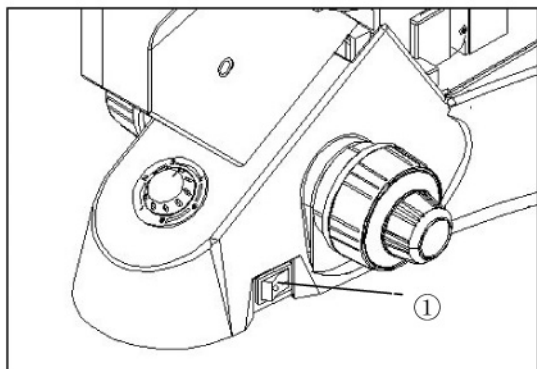

Fig. 15

ADJUSTMENT AND OPERATION

Turning On The Lamp

(Figure 15)

Connect the power cord, then set the main switch ① on the side of the base to the “on” position (“-”).

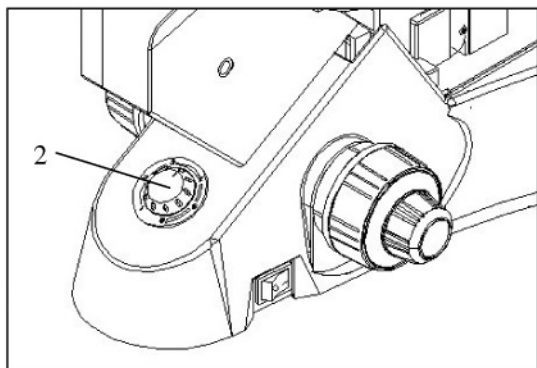

Fig. 16

Adjusting The Brightness

(Figure 16)

Rotate the brightness adjustment knob (2) clockwise to increase the brightness. Conversely, rotating the knob decreases the brightness.

Using the lamp at its lowest acceptable intensity will increase the life of the lamp.

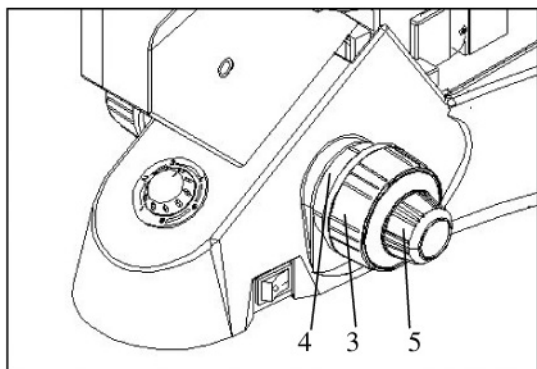

Fig. 17

Adjusting the Tension

Adjustment Collar

(Figure 17)

The tension of the coarse focusing knob (3) has already been properly adjusted.

Use the supplied tension adjustment wrench to adjust the tension adjustment collar (4).

Rotating the collar clockwise increases the tension on the coarse focusing knob. A counter-clockwise rotation will decrease the tension on the coarse focus knob.

The coarse focusing knob is too loose if the nosepiece descends on its own or if the specimen loses its focus shortly after focusing with the fine focus knob (5). Adjust the tension adjustment collar so these do not occur.

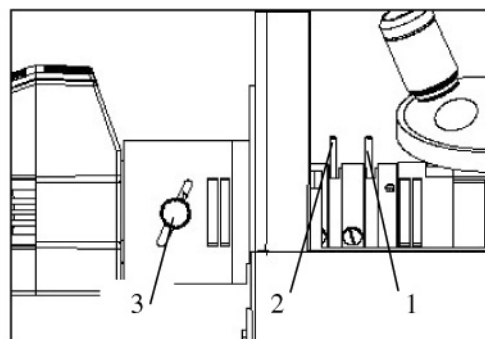

Fig. 18

Adjusting the Illumination (Figure 18)

1. Make sure the field of view is bright and evenly illuminated, and has no filament shadow. If there is filament shadow, adjust the condenser adjustment knob③ to its proper position.
2. To obtain a clear, sharp image, adjust the field iris diaphragm① and aperture iris diaphragm (2) to their proper positions. One or both diaphragms may need to be adjusted to obtain the sharpest image.

Aperture Iris Diaphragm: The aperture iris diaphragm is not used to control the brightness of the image. It controls the aperture angle of the incident rays. The diaphragm is not adjusted properly until the incident rays just fill the objective lens. At this position, the contrast and sharpness of the image will be the best. The aperture diaphragm should be re-adjusted when changing objectives.

Field Iris Diaphragm: The field iris diaphragm is used to control the size of the field of view, reduce the reflected rays and glare, thereby increasing the contrast of the image. Generally, the field iris diaphragm is at the proper setting when the rays just fill the field of view of the eyepieces.

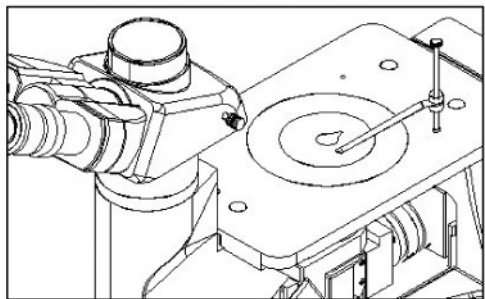

Fig. 19

Placing and Moving the Specimen (Figures 19 & 20)

1. Place the slide in the center of the stage and secure with the stage clip.
2. The specimen may be moved to different positions by turning the X-axis knob ① and/or the Y-axis knob ②.

Travel: X-axis (left-right) direction: 120mm
Y-axis (front-back) direction: 78mm

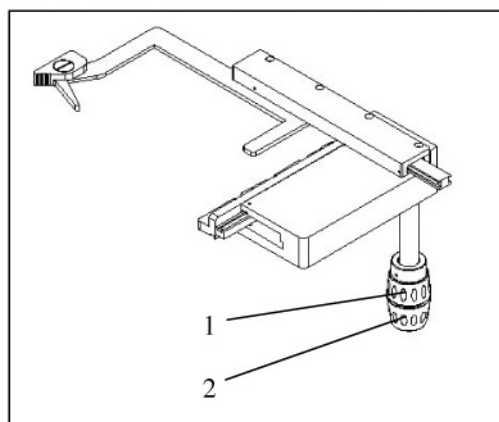

Fig. 20

Use caution when changing the objective to prevent it from touching the stage, stage plate or specimen slide.

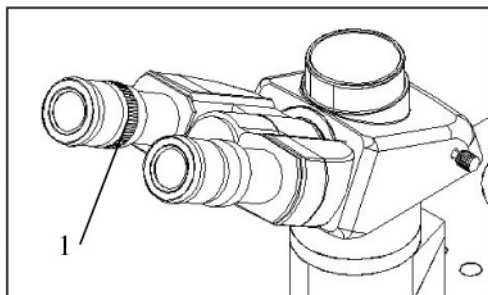

Fig. 21

Adjusting the Diopter

(Figure 21)

1. Looking through the right ocular only with your right eye, use the coarse and fine focusing adjustment knobs to focus on the specimen.
2. Then with your left eye only, look through the left ocular. If the image is not sharp, rotate the diopter adjustment ring ① to focus on the specimen.

Diopter adjustment range: ± 5

Adjusting the Interpupillary Distance

(Figure 22)

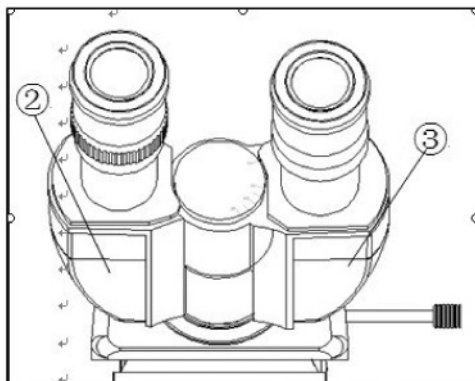

Fig. 22

While observing with both eyes, hold the left and right prism holders (2 & 3), rotate them around the axis to adjust the interpupillary distance until the left and right fields of view coincide to form a single image.

Interpupillary range : 48 ~ 75mm

Switching the Light Path

(Figure 23)

Pull out or push in the light path selector lever (4) to select the light path required.

For the binocular observation, push the lever in completely. For video or microphotography, pull the lever out completely.

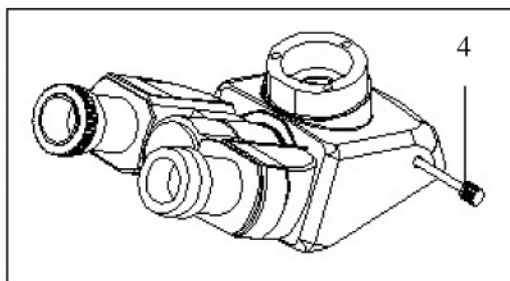

Fig. 23

MEC2 INVERTED METALLURGICAL MICROSCOPE

Light Path Selecting Lever	Illumination	Application
Pushed In	100% for binocular observation	Binocular observation
Pulled Out	20% for binocular observation 80% for video or microphotography	Binocular observation and video (CCTV) or microphotography simultaneously

Polarization Observation

1. Insert the polarizer and analyzer as described on page 8 (Figures 10 & 11).
2. The analyzer hand wheel can be rotated from 0 ° to 90°. When the field of view becomes the darkest, the polarization position has been obtained and polarized observation can be performed.

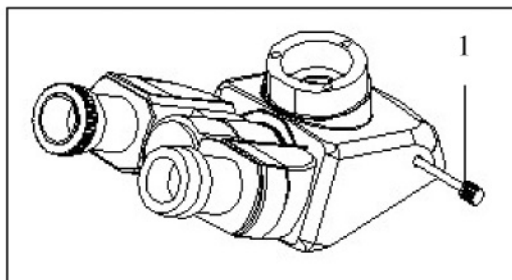

Fig. 24

MICROSCOPE VIDEO AND PHOTOGRAPHY

Video Microscopy

Selecting the Light Path (Figure 24)

1. Push in the light path selector (1) completely.
2. Using binocular observation, focus your specimen.
3. Pull out the light path selector completely.

Installing the Video Adapter (Figure 25)

1. Loosen the thumb screw ① on the trinocular viewing tube, and remove the dust cap ②.
2. Remove the dust covers on the both ends of the video adapter ③.
3. Insert the flanged end into the trinocular viewing head and tighten the thumb screw.
4. The threaded video C-mount should be facing upwards.

MEC2 INVERTED METALLURGICAL MICROSCOPE

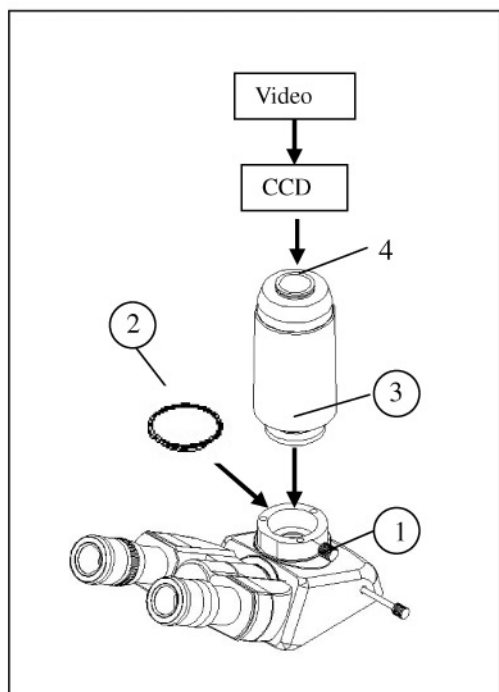

Fig. 25

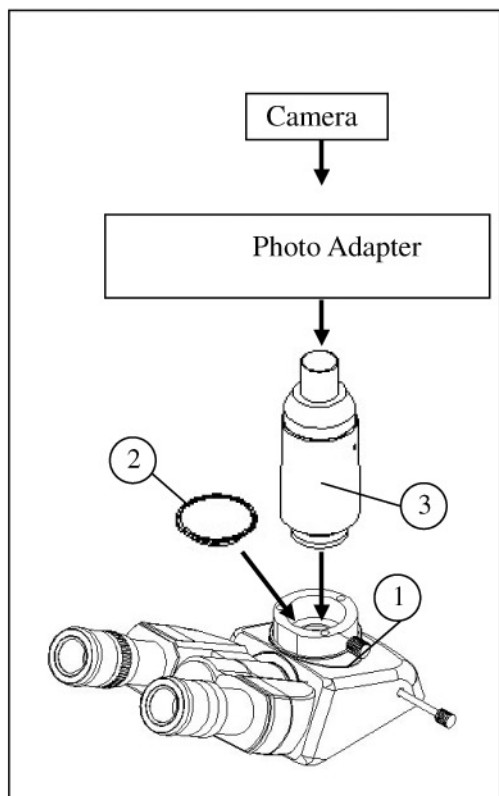

Fig. 26

Focusing (Figure 25)

Observing through binocular position, focus the specimen until a sharp image is obtained. Then check the image on the monitor to which the microscope is connected. If the image is not sharp, rotate the video adapter (4) until the image is sharp.

Microscope Photography (Figure 26)

Selecting the Light Path (Figure 24)

Follow the instructions on previous page

Installing the Photo Adapter (Figure 26)

1. Loosen the thumb screw ① on the trinocular viewing tube and remove the dust cap ②.
2. Install the photo accessory adapter into the trinocular port and tighten the thumb screw ①.
3. Connect the photo adapter with the camera. Then insert the adapter into the photo accessory adapter ③.

To avoid disturbing the image focus, place the camera viewfinder toward the front of the microscope when installing the camera.

The magnification of photomicrograph = magnification of objective x magnification of the photo adapter.

The shutter on some cameras may cause a jarring impact when photographing through the microscope. To weaken the impact and obtain a clear, sharp image, select a longer exposure time.

Focusing

Focus the specimen using binocular observation. Then, for microphotography, focus the camera.

Adjusting the Color Temperature

When photographing with sunlight film:

1. Mount the blue filter into the filter bracket.
2. Turn the brightness adjustment knob to the maximum limit. This allows you to obtain sunlight illumination.

MEC2 INVERTED METALLURGICAL MICROSCOPE

SPECIFICATIONS

Optical System	Infinity Optical System
Viewing Tube	Siedentopf style; Trinocular Tube; Inclined 30°; Diopter Range: ±5; Interpupillary distance range: 48mm -75mm Standard configuration light distribution: Binocular 100% or Binocular/photo 20%/80%
Eyepiece	Extra Wide Field 10x with 20mm field of view with diopter adjustment and eyeguards
Nosepiece	Quintuple nosepiece with positive click stops
Objective	Plan achromatic objectives: 5x, 10x, 20x, 40x
Focusing System	Coaxial coarse and fine focusing adjustment; Vertical objective movement; Coarse focus: 377mm per rotation; Fine focus: 0.2mm per rotation
Stage	Area: 160mm x 250mm
Mechanical Ruler	X/Y Coaxial Control; Right hand low position Movement range: 120mm x 78mm
Illumination	6 volt 30 watt halogen; variable intensity; External lamp housing for Kohler illumination
Filters	Blue, yellow, green and ground glass

OBJECTIVES

Magnification	Aperture Number (N.A.)	Working Distance (mm)	Conjugate Distance (mm)
5x	0.12	15.4	∞
10x	.25	11	∞
20x	0.4	6	∞
40x	0.6	3.7	∞

TROUBLESHOOTING

Under certain conditions, performance of this unit may be adversely affected by factors other than defects. If a problem occurs, please review the following list and take remedial action as needed. If you cannot solve the problem after checking the entire list, please contact your local dealer for assistance.

OPTICAL

PROBLEM	CAUSE	CORRECTIVE MEASURE
Darkness at the periphery or uneven brightness in the field of view	Revolving nosepiece not in click stop position	Turn the nosepiece to click-stop position so the objective is in the optical path
Dirt or dust on the viewfield	Dirt or dust on the lens, eyepiece, condenser, objective, collector lens or specimen	Clean the lens
Poor image quality	Condenser aperture is closed or open too much Condenser is positioned too low	Open or close properly Position the condenser at the upper limit

IMAGE PROBLEMS

Image moves while focusing	Specimen rises from stage surface Revolving nosepiece is not in the click-stop position	Secure the specimen with the holder Turn the nosepiece to the click-stop position
Image tinged yellow	Blue filter not used Lamp intensity is too low	Use daylight blue filter Adjust the light intensity by turning the intensity control dial
Image is too bright	Lamp intensity is too high	Adjust the light intensity by turning the intensity control dial
Insufficient brightness	Lamp intensity is too low Aperture diaphragm closed too far Condenser position is too low	Adjust the light intensity by turning the intensity control dial Open to the proper setting Position the condenser to the upper limit
Lamp does not light when switched on	No electrical power Lamp bulb burnt out Fuse blown out	Check power cord connection Replace bulb Replace fuse
Slippage of focus when using the coarse focusing knob	Tension adjustment is set too low	Increase the tension on the focusing knobs
Fine focus is ineffective	Tension adjustment is set too high	Loosen the tension on the focusing knobs

MAINTENANCE

Please remember to **never** leave the microscope with eyepieces removed and always protect the microscope with the dust cover when not in use.

SERVICE

UNITRON® microscopes are precision instruments which require periodic servicing to keep them performing properly and to compensate for normal wear. A regular schedule of preventative maintenance by qualified personnel is highly recommended. Your authorized UNITRON® distributor can arrange for this service. Should unexpected problems be experienced with your instrument, proceed as follows:

1. Contact the UNITRON® distributor from whom you purchased the microscope. Some problems can be resolved simply over the telephone.
2. If it is determined that the microscope should be returned to your UNITRON® distributor or to UNITRON® for warranty repair, pack the instrument in its original Styrofoam shipping carton. If you no longer have this carton, pack the microscope in a crush-resistant carton with a minimum of three inches of a shock absorbing material surrounding it to prevent in-transit damage. The microscope should be wrapped in a plastic bag to prevent Styrofoam dust from damaging the microscope. Always ship the microscope in an upright position; **NEVER SHIP A MICROSCOPE ON ITS SIDE**. The microscope or component should be shipped prepaid and insured.

LIMITED MICROSCOPE WARRANTY

This microscope is warranted to be free from defects in material and workmanship for a period of five (5) years for mechanical and optical components and one (1) year for electrical components from the date of invoice to the original (end user) purchaser. This warranty does not cover damage caused in-transit, misuse, neglect, abuse or damage resulting from improper servicing or modification by other than UNITRON® approved service personnel. This warranty does not cover any routine maintenance work or any other work, which is reasonably expected to be performed by the purchaser. Normal wear is excluded from this warranty. No responsibility is assumed for unsatisfactory operating performance due to environmental conditions such as humidity, dust, corrosive chemicals, deposition of oil or other foreign matter, spillage or other conditions beyond the control of Unitron Ltd. This warranty expressly excludes any liability by Unitron Ltd. for consequential loss or damage on any grounds, such as (but not limited to) the non-availability to the End User of the product(s) under warranty or the need to repair work processes. Should any defect in material, workmanship or electronic component occur under this warranty contact your UNITRON® distributor or UNITRON® at (631) 543-2000. This warranty is limited to the continental United States of America. All items returned for warranty repair must be sent freight prepaid and insured to Unitron Ltd., 73 Mall Drive, Commack, NY 11725 – USA. All warranty repairs will be returned freight prepaid to any destination within the continental United States of America. For all foreign warranty repairs, return freight charges are the responsibility of the individual/company who returned the merchandise for repair.